

THE SESQUIPLANES

by D.H.R. White

Strictly speaking, the term sesquiplane means "a biplane aeroplane having one pair of wings, - usually the lower, - of half the area of the other pair." However, the definition applying in this discussion is the simpler one "a biplane having lower wings of distinctly less area than the upper ones." It is a subject which naturally confines itself to fighter types because very few larger aeroplanes of The Great War period had large differences between upper and lower wing area, and in the writer's opinion "upper wing extensions do not make a sesquiplane"! There must some reduction of chord unless the reduction of the span of the lower wings is great. For this reason such types as the Blackburn "Kangaroo" and Handley Page O/400 do not qualify as sesquiplanes.

The subject will be studied here by consideration of three questions -

- 1.) What were the structural features of sesquiplanes and what effect did they have in their history?
- 2.) Which aeroplanes qualify as sesquiplanes and why was there a great imbalance in use by the major combatant nations?
- 3.) What were the strategic and tactical considerations which affected their operational use?

Structural

The earliest sesquiplanes appeared during that fascinating period of aeronautical history, - the first ten years before The Great War but none attained particular prominence. The wing structure of those days showed, in their wonderful variety, how bold and free was the thinking of the pioneers. From simple monoplanes to bizarre multiplanes the "flying machines" attempted to master the new element with varying degrees of success. By 1912 things had begun to settle into a pattern. Monoplanes gave the best performance. The power-to-weight ratio of the rotary aero engine made it the most suitable. The French led the world in heavier-than-air machines largely because they manufactured motors. The biplane then only justified its existence by virtue of its strength and ease of construction; altitude records were often held by monoplanes. The future seemed to lie with the sporting little monoplane in those years when the Antarctic adventure of Amundsen, Shackleton and Scott, the loss of "Titanic", "Votes for Women" in Britain, and the usual selection of minor wars, competed for headlines with early aviation.

Then two things happened; aero engines increased in power, and the military authorities began to realise that the aeroplane might be useful in war after all.

The increase in engine power and weight-carrying requirements called for larger planes but the techniques of monoplane construction fell behind engine development. They were mostly constructed in the current mode using wood, wire and fabric, with wings of thin, heavily cambered aerofoil section. Increases, first in engine weights, then in size, led to dangerous weaknesses. Racing had inevitably promoted a search for more power and the monoplane was still the racing machine. The military authorities, especially in Britain, could only envisage one use for the aeroplane - reconnaissance. Also, because none of them had any practical experience, they believed that low altitude observation was essential.

With these views in mind it followed that they demanded a slow-flying, stable aeroplane as the only type from which useful observing work could be carried out. To add fuel to their fire (if one can call such comparative lethargy fire!) there were several fatal accidents involving monoplanes. Without waiting for design and construction techniques to cope with the problem, with typical British decisiveness, the British Army damned the monoplane in

THE SESQUIPLANES (Continued)

the famous "ban" of 1912. However, one cannot help being somewhat facetious in pointing out that their aversion to the monoplane did not prevent them from accepting Bleriot monoplanes for service when they realised how far behind the French and Germans they were!

In this situation, at the critical moment, the B.E.2 appeared. On 12th August 1912 G. de Havilland, - who with F.M. Green had been responsible for the design, - broke the British altitude record. This inherently stable machine gained in popularity, due, in no small measure to the clean reliability and quiet efficiency of its in-line engines, - Wolseley and Renault. This aeroplane and its derivatives became so much in favour that about 4,000 were built, - many after the type was completely obsolete.

It must have appeared as the perfect justification of the decision to ban the monoplane, when the first R.F.C. men to be killed on active service, - Lieut. Skene and A. Mech. Barlow, - died in the shattered remains of their Bleriot XI monoplane shortly after take-off in England on 12th August 1914, - strangely enough two years to the very day after the B.E.2 had captured the altitude record.

The biplane had many real advantages, - the wing cellule was relatively strong, inherent structural strength being augmented by rigging with ample attachment points giving angles of advantage. The lower wing afforded convenient arrangement of control wires for wing warping or ailerons and once lower wing ailerons came into general use, far superior lateral control was afforded.

Most important of all in the safety consideration, aeronautical mathematicians, being largely recruited from, or trained in the traditional methods of, the civil structural field, were capable of calculating static stressing factors based upon the well-tried premises of the construction of bridges and cranes. There were no such ready methods applying to monoplanes, - cantilever or otherwise. Even with the biplane, flying loads and stresses were not thoroughly understood for at least the first twenty years of powered flight. Indeed, there has always been that exciting if dangerous element of trial-and-error in aeroplane design without which test pilots would be mere performance evaluators.

The Nieuport XI "Bebe", was the development of an enterprising design by Gustave Delage, from an original concept by Franz Schneider. This little aeroplane, which arrived on the Western Front about July 1915 was light, simple, and like most successful designs of the period, it "looked right". It established the tractor biplane as the ideal offensive type just as the Sopwith "Tabloid" had established it as the ideal fast Scout. Most of the lift and strength of the equal chord and span biplane were achieved with much reduced drag. Manoeuvrability was superb due to generous control surfaces, weights concentrated closely about the centre of gravity, and the wide gap-small lower wing combination which minimised inter-plane interference. But the factor that made the design was that it was so capable of development. Finer lines and a more powerful motor in the XVI and the XVII which reached the front in May 1916 produced a scout that was in use until mid 1917 on the Western Front and would have lasted longer but for two factors, - single gun fighters were obsolete in 1917 (very few XVIIIs were fitted with Vickers and Lewis), and speed and strength were not quite up to the standards of its later contemporaries. I do not consider that speed was a major factor; the F.1 "Camel" at 113 m.p.h. and the Fokker Dr.1 at 102 m.p.h. bracketed neatly the Nieuport XVII at 107 m.p.h. Remember also that Albert Ball was very disappointed with the S.E.5 in comparison with the Nieuport, getting the early impression that the S.E. was SLOWER!

There were several cases of lower wing failures in Nieuport and Albatros "V-strutters", due mainly to the single spar being subject to twisting moments. However, remember that

NIEUPORT XI

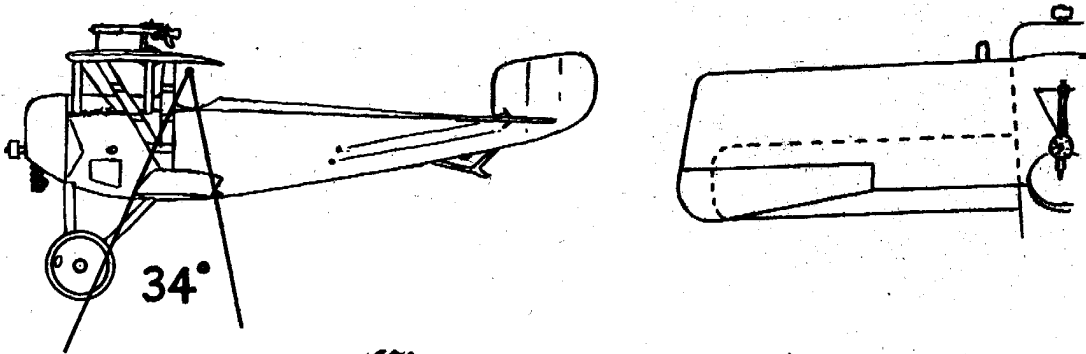

Siemens-Schuckert D.I

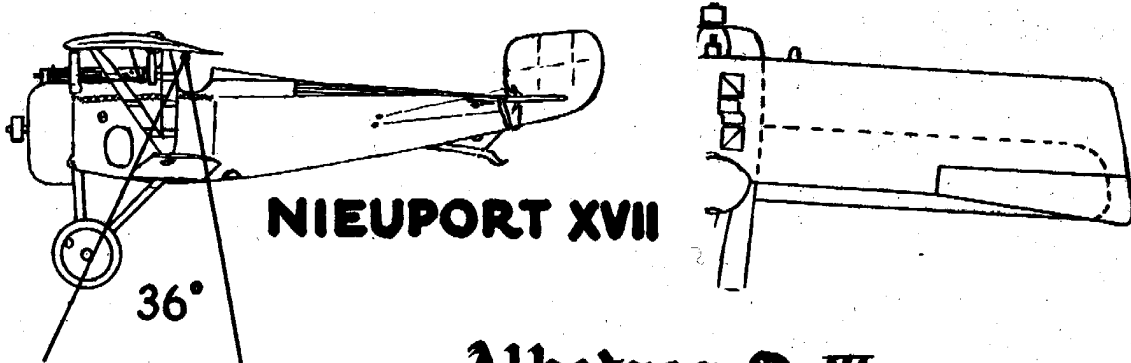
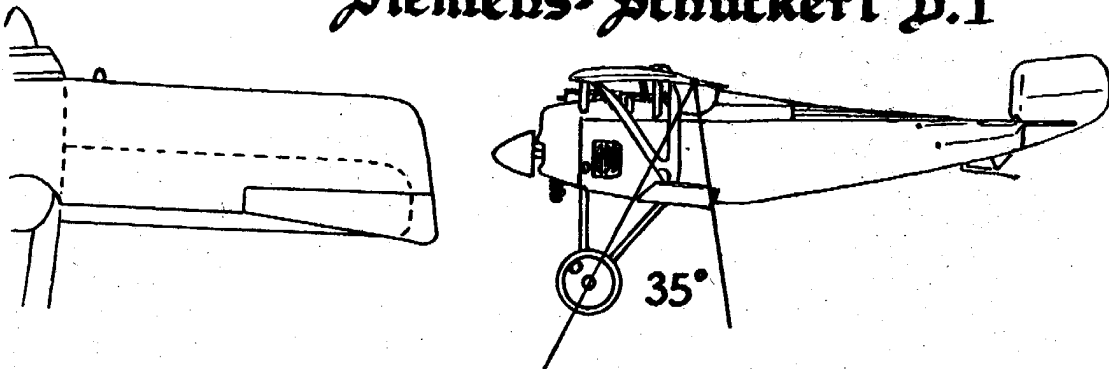

NIEUPORT XVII

Albatros D. III

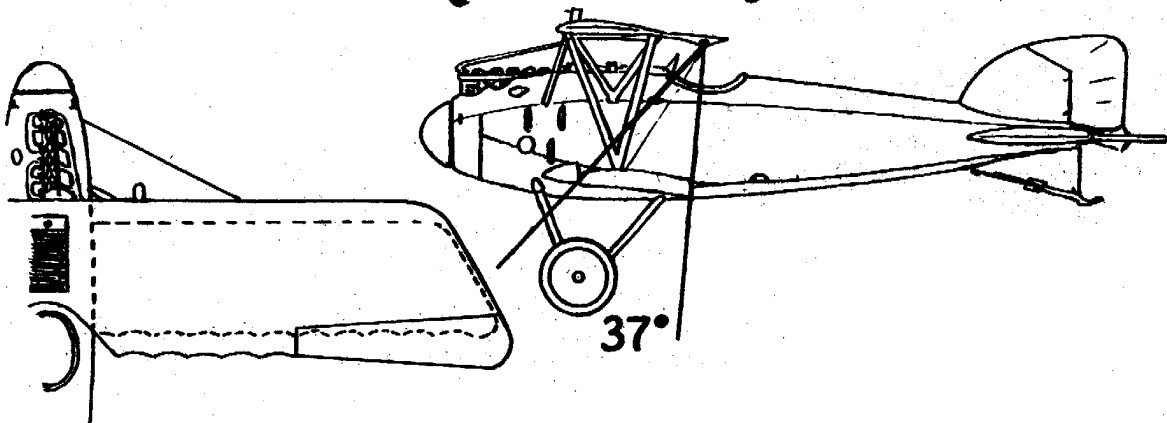

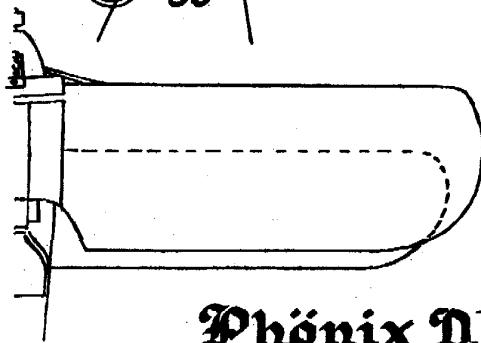
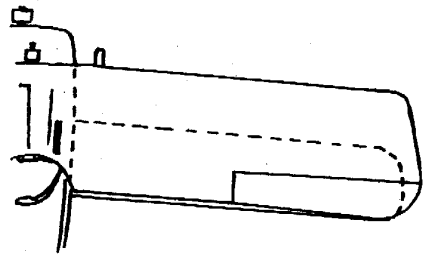
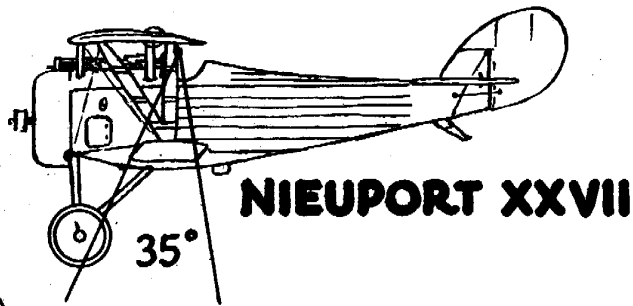

Phoenix D.III

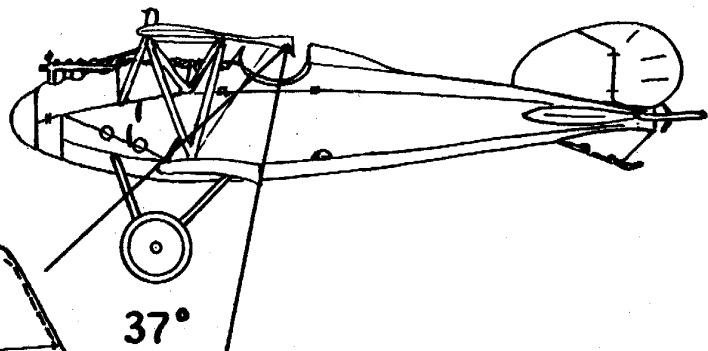
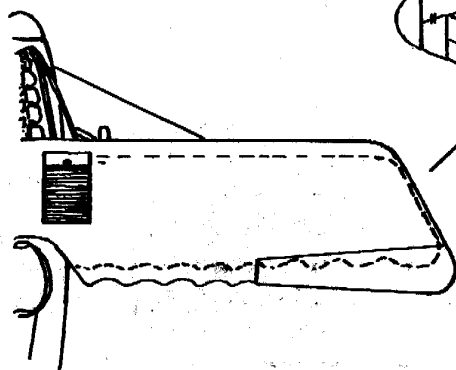
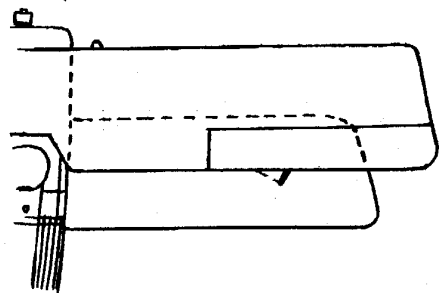
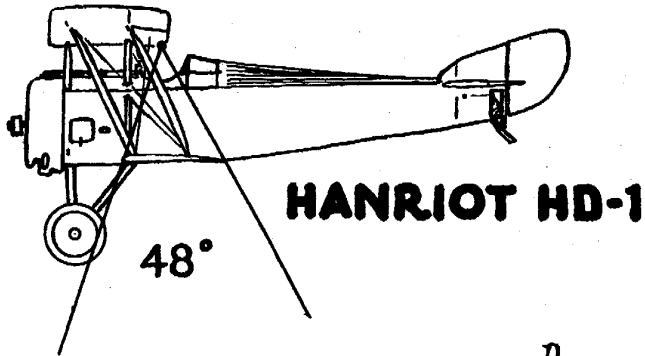
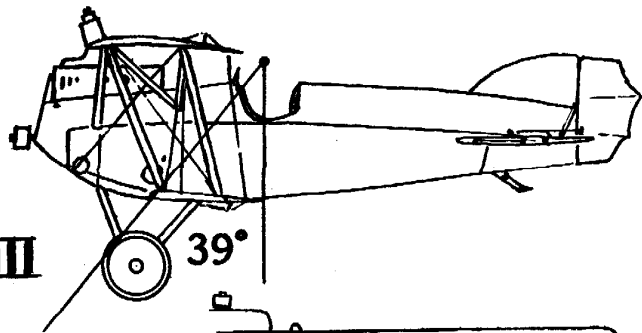

Albatros D.V-Va

THE SESQUIPLANES (Continued)

among failures there were also safe landings using what was left! - This says volumes for the structural length of upper wings and cabane struts. (And let it not be forgotten that Major F. W. Goodden lost his valuable life when the prototype S.E.5 A.4562 suffered a wing failure after extensive tests.)

The well known auxiliary struts of the Albatros D.V/Va, which were not universally fitted to either type, were a modification to combat this weakness. Their only partial success was no doubt the reason why the modification was not universal.

The lower wings of the Albatros "V-Strutters" were not as small in span or chord as those of the Nieuports in comparison to the upper wings; the potential twisting moment could therefore be expected to have been greater and it must be deduced that only extra inbuilt strength in the Albatros wing cellule. Indeed, the construction of Nieuport and Albatros 'V' struts was entirely different, the former having spruce struts bound in three places on each "leg"; the German V struts were of streamlined section steel tubing.

Similarly the wing construction of the two differed widely, the Albatros incorporating steel tube compression members and steel tube aileron frames, extensive use of ply wood and wire trailing edges. In the Nieuport wings, the only use of steel tube was in the mounting for the ailerons, the wings being essentially of soft and hard wood construction. The very ingenious aileron control system of the Nieuport, with its distinctive quadrants in the wing slots and absence of wires in favour of rods throughout was not adopted in the Albatros in which the crank arms, sited in the middle of the ailerons, were operated by cables. The upper wing of the Nieuport XVII was at the average pilot's eye level, giving a superb view ahead; the Albatros D.III wing was sited higher and comparative gaps were 4' 1" and 4' 10½".

Types of Sesquiplanes.

The Nieuport Scouts from the XI to the XXVII, manufactured not only by the French but by the British and the famous Italian Macchi-Nieuport concern; the Albatros D.III, D.V/Va, German and Austrian; and the Pfalz D.III/IIIa are so justly famous and were produced in such numbers, that a singular fact is easily overlooked. This is that a thorough search of British types fails to reveal even one operational sesquiplane of 1914-18 other than the Alcock Scout, built at Mudros from hybrid parts!

Even when one looks at the field of types that were rare, purely experimental or produced at the end of the war, the list is amazingly short, - the Avro "Spider" Scout, the Port Victoria P.V.7 "Grain Kitten", the Vickers FB 12, and 24 'A' and 'B' two seaters and the experimental and much modified S.E.5b during some of its life.

Of course the British did build Nieuports, particularly type 24 bis by the British Nieuport Co. of Hendon, but the majority of those in British colours were supplied by the French. When we examine the German situation, a very different story emerges. As is well known, the gradual decline of the Fokker Eindekker monoplane was largely due to the superior performance of the Nieuports in the French sectors and the increasing, aggressive use of British "pushers" in theirs. So impressed were the Germans by the performance of the agile little Nieuports in comparison with the Eindekkers, which had never really been more than "just a very ordinary aeroplane with a synchronised gun", that they "went overboard" for the sesquiplane design, just as later, under the spell of the Sopwith Triplane they ran riot with a large number of triplane projects.

The Siemens-Schuckert D.I and D.Ia and the Euler D.I were almost exact copies of the Nieuports and the Rex D and L.V.G. D.II bore a strong resemblance. The Roland D.III exhibited some slight influence from them too.

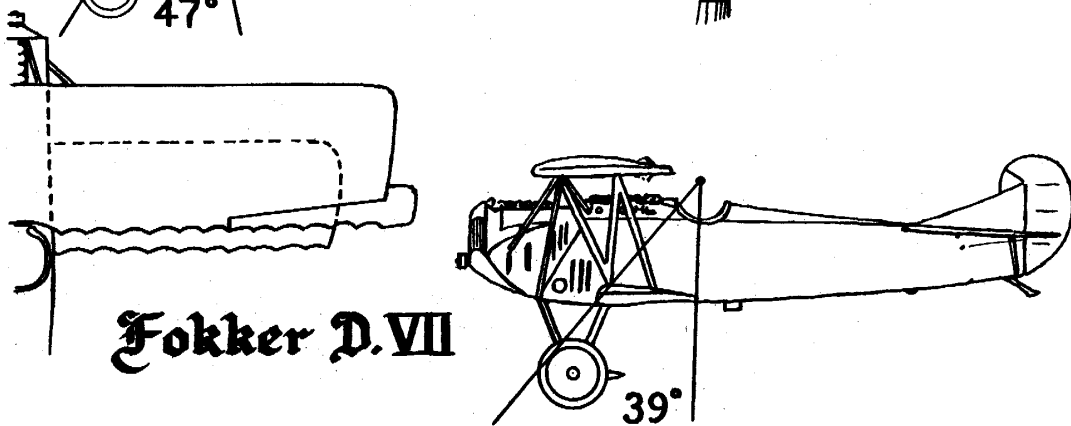
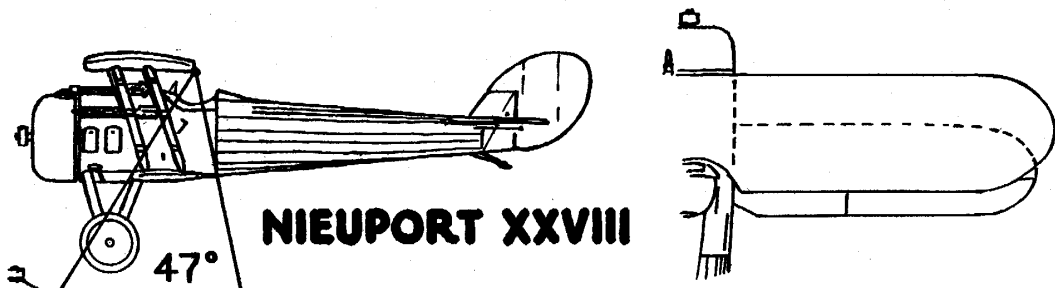
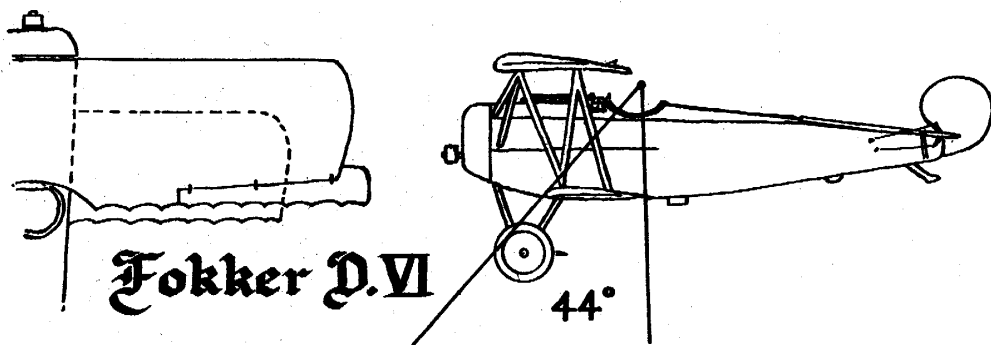
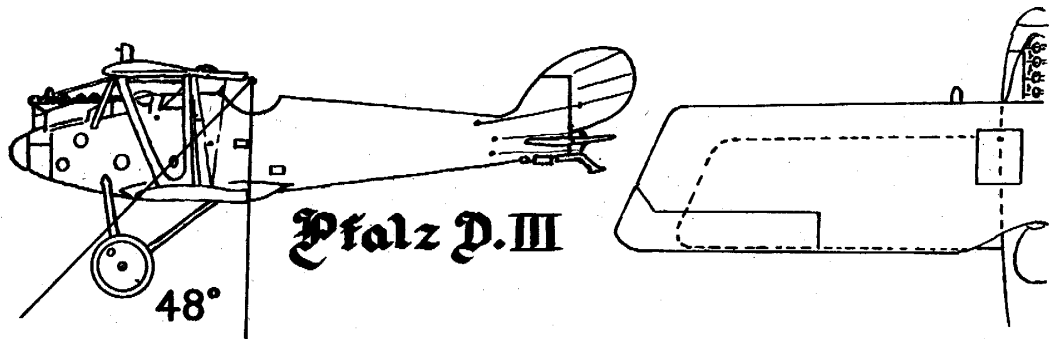

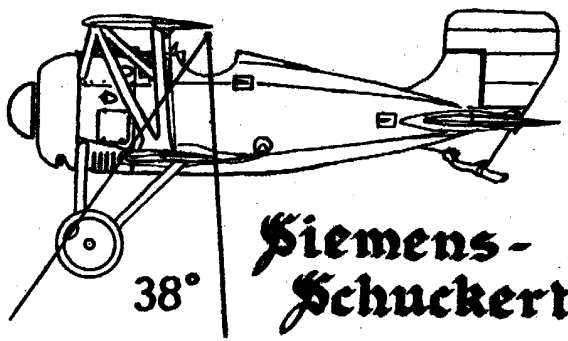

38°

Siemens-Schuckert D.III

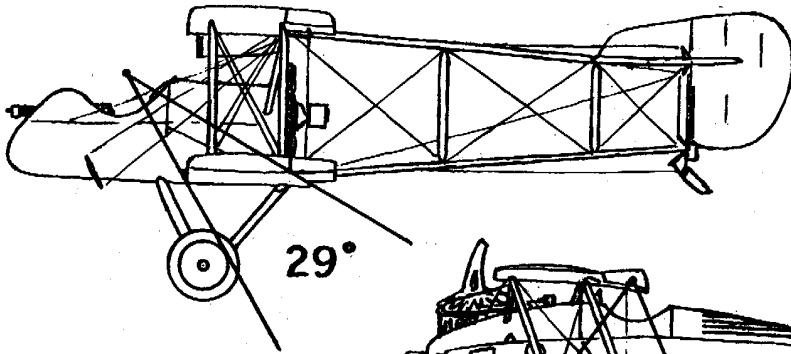
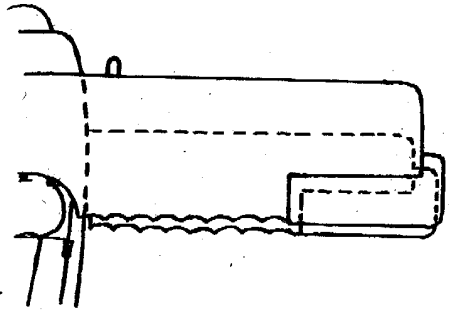

29°

Halberstadt D.II

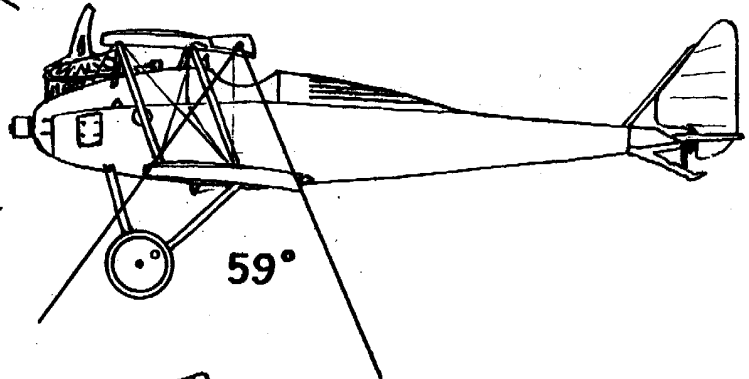

59°

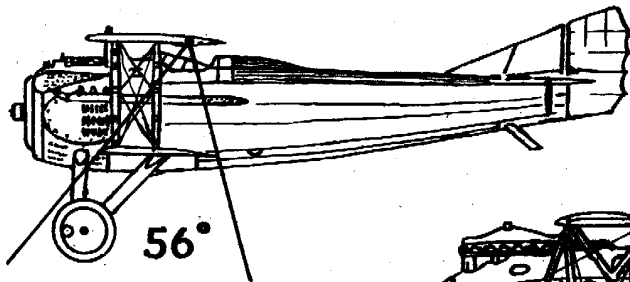

56°

Albatros D.II

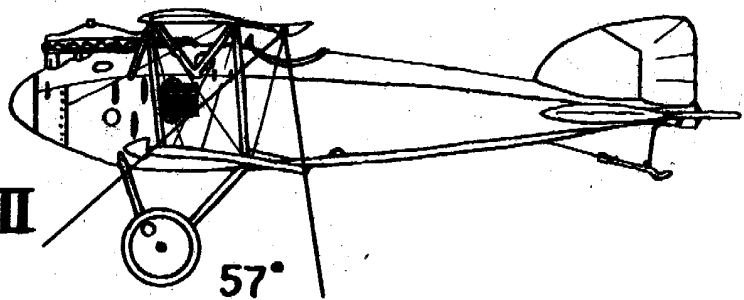

57°

THE SESQUIPLANES (Continued)

Not only did the Albatros D types survive until the end of the war, but a check over the later German types reveals that a great number of both single and two seat fighters were sesquiplanes or neo-sesquiplanes. These include the Fokker D.VI, D.VII and D.VII F, Hannover CL.II, III and IIIa, Junkers J.I, Albatros D.XI, Aviatik D.VI, B.F.W. CL.II, Brandenburg W.XVI and L.XIV, Daimler D.I, Kondor D.I and D.VII, L.V.G. D.IV and D.VI, and the Siemens-Schuckert D.III; also the experimental Fokkers V.13 and V.33 and the unorthodox Geest single seater.

Apart from the French types already listed, two more well known ones qualify as sesquiplanes, -the Hanriot HD.I and, perhaps unexpectedly, the Nieuport 28.

One famous Austrian scout must be listed, - the Phönix D.III.

But to return to German types, the greatest enigma was perhaps the Pfalz D.III. Beautifully constructed and incorporating the ingenious close, double spar lower wings with struts somewhere between 'V' and 'U' giving so much more strength than any similar arrangement. For some reason, perhaps due to its weight, - the performance was not up to the expected standard. The weight did indeed exceed that of its contemporaries by quite appreciable amounts whereas the same Mercedes engines were used. It was produced in quantity and widely used but apart from its fine strength, never received the enthusiastic reception from top line aces which the Albatros D.III and Fokker D.VII did. It was said to be a very fine aeroplane for attacks on balloons.

Strategic and Tactical

The view from the cockpit of a sesquiplane was naturally well above average. It has been held that this was of especial advantage when landing but an experienced Nieuport pilot told me that this was absolute nonsense because one of the most serious and elementary mistakes that could be made was to watch the ground below when landing, instead of the view ahead.

The excellent view below was valuable in a scout aeroplane in four ways:-

- 1.) Spotting hostile aeroplanes of all types at lower altitudes when on offensive patrol, and attacking them.
- 2.) Sighting enemy scouts rising to intercept friendly, escorted aeroplanes engaged in artillery observation, photography, bombing or other special missions.
- 3.) Better view for contact patrols.
- 4.) Better view for ground strafing, balloon attacks, and the low altitude flying on the return from such attacks.

While mentioning balloon attacks it can be noted that a monoplane would not have been suited to the fitting of the Le Prieur rockets which found an ideal location on the 'V' interplane struts of the Nieuports. Another armament feature arose out of the lack of a synchronising gear and the consequent use of a Lewis gun above the top plane. The Foster mounting allowed mobility of the Lewis, while retaining sufficient rigidity. The exploitation of this by Ball and some of his successors in "belly attacks" is well known.

The Fokker Eidekkers operated at altitude, attacking in dives. Climbing capabilities were important from the first days of air fighting and superior altitude always an advantage of the greatest value. The fine climb and manoeuvrability of the Nieuports made them both excellent protectors and interceptors.

They, and the sesquiplanes which followed them, proved themselves in combat on both sides, and the influence was evident in single seat fighter design for twenty years after the first little Nieuport XI's rose to do battle.

THE SESQUIPLANES (Continued)

It will be recalled how the early military thinking demanded slow flying for low altitude reconnaissance, there being a lack of appreciation of how vulnerable the aeroplane could be to ground fire. Lower flying speed and lighter wing loading brought the ability to take off and land on small, rough fields with greater safety than the monoplane could have easily been designed to do. Undoubtedly the crew or a biplane had better protection in crashes, especially of the inverted variety.

From the point of view of vision alone, the parasol type was of course superior, but apart from the structural and other considerations already discussed for monoplanes in general other points arise; - bombs could only be carried in or under the fuselage. Weights underneath the wing were dangerously high above the centre of gravity and would affect lateral control severely, especially when uneven due to a "hang-up". The Morane Parasols were the only ones of their type to do a significant amount of work for any of the combatant nations. They carried light bombs in the fuselage.

As always, the enthusiastic and imaginative student can find many fascinating "might-have-beens", and some mysteries. It would be an interesting exercise to contemplate a Nieuport XVII CI with a Bentley B.R.2 rotary motor and twin Vickers guns. How would it have compared to the "Camel"? - Or how about a B.M.W. engined Pfalz D.III?

On the British side, the excellent Siddeley "Siskin" sesquiplane suffered the disgraceful engine problems which dogged so many types that it has been stated that the air war would have been lost if it had gone on into 1919. Anyway, it was not flying until December 1918, so scarcely qualifies as a wartime type. It was however the basis of many designs of the twenties, including the Bristol "Bulldog" of happy memory.

Two mysteries are, - why did the first German sesquiplane of note, - the Albatros D.III - not enter service until early 1917, when the Nieuport had appeared as early as the summer of '15?

And why did the British "wait" until after the war to put a sesquiplane into R.A.F. service?

In attempting to answer these questions it must be stated that there is more deduction involved than research. Early Nieuport production details must be among the worst documented statistics; much Albatros information went missing between 1918 and 1945.

Firstly it is unlikely that the Nieuport Bebe was seen in quantity until early 1916 and by the time that they had made such an impression upon the German authorities and examples had been captured, two further considerations had presented themselves.

These were that the Albatros D.I was already well under way (it came out in the summer of '16) and that the improved Nieuport XVII had been seen and was still subject to evaluation. Moreover the Albatros D.I/II when it appeared in service quickly proved distinctly superior to all contemporary scouts except the Sopwith Scout ("Pup") and SPAD VII in some aspects of fighting. It appears that the Albatros Werke were not to be rushed into a new design when the D.I and II were going well, - even by the military authorities. Otherwise they would scarcely have taken nearly a year to comply with Idflieg's request. Also it must have been rather a shock for a company working entirely upon stationery engined aeroplanes to be requested to incorporate features from an entirely different rotary engined scout! Compare the rapidity with which, for instance, the Fokker Dr.I triplane progressed from drawing board to operations.

It has been stated that Robert Thelen commenced the design of the Albatros D.III just as D.II production started. Work was found to be necessary in the fields of engine, radiator and of course wings. Much of the time must have been taken up with testing of wings to attempt

THE SESQUIPLANES (Continued)

to avoid the weaknesses evident in the captured Nieuports.

The question of British neglect of the sesquiplane form is harder to answer but again it may have been a matter of timing and commitment. The Nieuport XVII was still doing good service with the British squadrons when the "Camel" and S.E.5 were selected for quantity production and at this time, no sesquiplane designs were coming forward. Also the British designers never seemed to heed the advice of front-line fighting pilots very much. Albert Ball complained bitterly to his father that things were not going as he had hoped with his proposals. One also recalls the excitement with which pilots awaited the Bristol M.1 monoplane which never had the chance to earn itself the reputation it deserved. Fighter trials of the German pattern might well have seen the Bristol come out on top of all contemporary single seaters in the absence of sturdy sesquiplanes.

Comparison of Visibility Factors.

The visibility from a fighting aeroplane can only be fully expressed as the percentage of a sphere having the pilot's head as its centre. This is very complicated to calculate and the following factors make it more difficult;-

- 1) Build of pilot. 2) Pilot's scope of head movement (suppleness, clothing etc.)
- 3) Adjustment of seat. 4) Reduction of visibility due to small items e.g. struts.
- 5) Cockpit size. 6) Widths of fuselage from nose to tail. 7) Cross section of fuselage.
- 8) Effects of cut-aways at wing roots. 9) Variable incidence tailplane effects where applicable.

In view of these difficulties, it appears sensible to examine the comparative visibility simply by comparison of the arcs in the vertical plane obscured by the lower wings.

In the accompanying diagrams, the position of the apex of the angle of obscurity has been taken at a point where the average pilot's eyes would be in a normal sitting position.

The results are interesting; a representative few aeroplanes of equal chord form have been selected to afford a comparison with the sesquiplanes illustrated. The case of the D.H.2 is of special interest; the principal credit factors of this aeroplane have usually been quoted as the clear field of fire ahead for the gun, and its manoeuvrability; - but look at the visibility factor for this equal chord pusher! Due to less chord and being set slightly further aft, the F.E.8 is even better, -27°. Of course, the views above and astern were inferior to those for a tractor scout.

It is necessary to show the Fokker E.V/D.VIII or other parasols, as their factors were virtually zero. Triplanes are also a special case; the angle of obscurity may be measured as for other types but there is the complication of the middle plane. In both the Sopwith and the Fokker this plane was not able to be positioned at the ideal level, - that of the pilot's eyes.

In both cases trailing root cut-aways were provided, - rectangular and curved respectively, - to improve the downward view. As the illustrations show, the results lie roughly between full chord and the sesquiplane.

Another interesting factor in all cases is expressed by the distribution of the total angle of obscurity about the vertical. In the Halberstadt, Hanriot, Sopwiths and Nieuports, the pilot's head is positioned roughly mid-chord. In the Fokkers, the Pfalz, Phönix, S.E., Spad and Siemens Schuckerts, it is close to or abaft the trailing edge.

These factors are among those which dictated the most favourable distribution and distances apart, horizontal and vertical, of aeroplanes of a particular type in formation flying. In the early days, when mixed formations were more often the rule than the exception, it must have been very difficult to operate efficiently. The difference in engine power and handling

THE SESQUIPLANES (Continued)

were of course the major considerations. Later, when the British and French operated one-type squadrons and escadrilles, the Germans often operated mixed formations of Fokkers, Albatros and Pfalz. Note that the angles and cockpit positions were very similar in all these aeroplanes, making formation keeping a little easier than it might have been.

Finally, what of the two-seaters? It is a well worn statement that a well built, well handled two seater was more than a match for a scout. With the two cockpits within touching distance and an alert crew, it must have been very difficult to "jump" a two seater. Once on the defensive, a fast one could safely run from attackers, which would have been a fatal move for a scout. Superb visibility and the "sting in the tail" made the reputation of the Bristol F2B, Albatros C.III and many other fine two seaters.

* * * * *

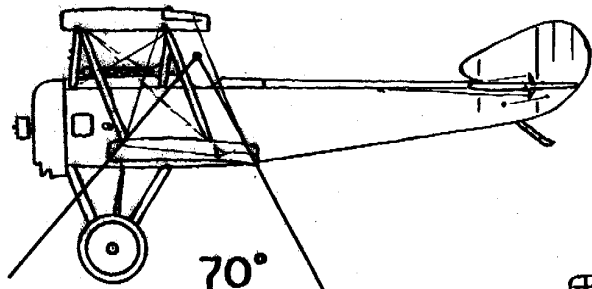

SOPWITH SCOUT

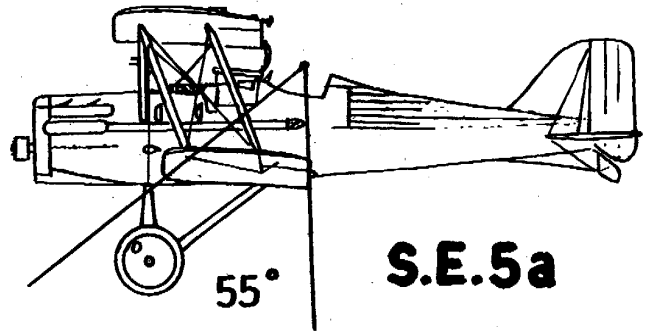

S.E.5a

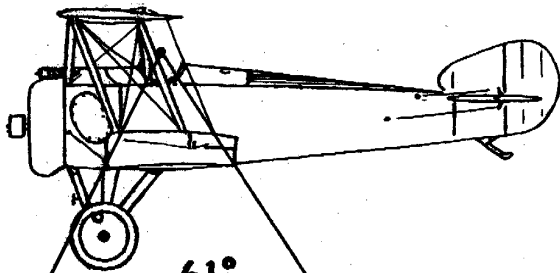

SOPWITH F.1

SOPWITH TRIPLANE

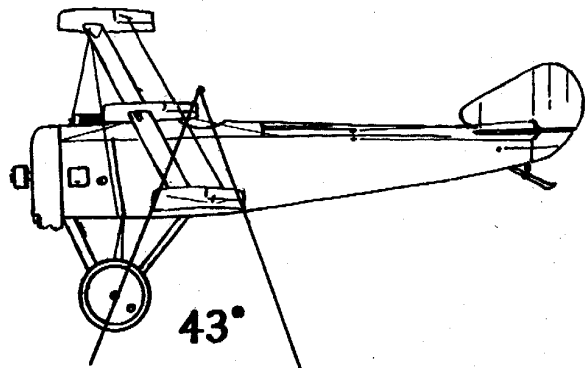

Fokker Dr.I

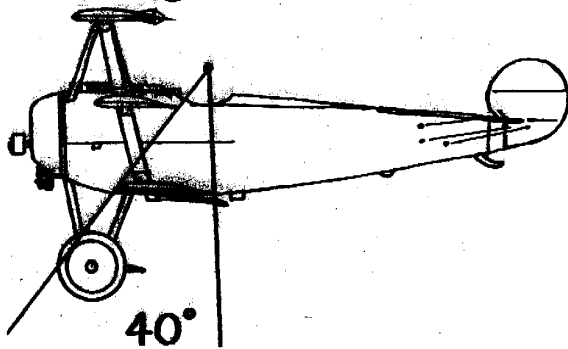

Pfalz Dr.I

